

## Circuit Analysis using Phasors, Laplace Transforms, and Network Functions

### A. Sinusoidal, steady-state analysis in the time domain:

For the  $RL$  circuit shown, KVL yields the following differential equation for  $i(t)$ :

$$L \frac{di}{dt} + Ri = V_o \cos \omega t$$

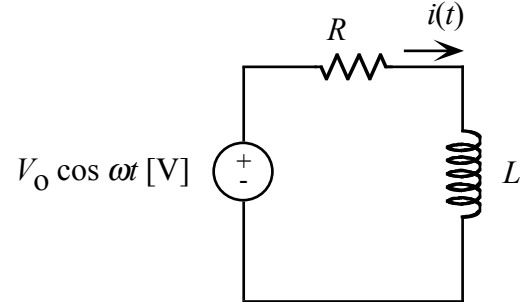

This can be solved by assuming  $i(t)$  to be of the form:

$$i(t) = I_m \cos(\omega t + \theta)$$

Substituting this into the differential equation yields:

$$-\omega L I_m \sin(\omega t + \theta) + R I_m \cos(\omega t + \theta) = V_o \cos \omega t$$

Using the trig identities for  $\sin(\omega t + \theta)$  and  $\cos(\omega t + \theta)$  makes this equation read

$$-\omega L I_m (\cos \theta \sin \omega t + \sin \theta \cos \omega t) + R I_m (\cos \theta \cos \omega t - \sin \theta \sin \omega t) = V_o \cos \omega t$$

Equating the  $\cos \omega t$  and  $\sin \omega t$  terms on the right and left sides yields

$$I_m (R \cos \theta - \omega L \sin \theta) = V_o \quad \text{and} \quad I_m (\omega L \cos \theta + R \sin \theta) = 0$$

These are easily solved for  $I_m$  and  $\theta$ , yielding

$$I_m = \frac{V_o}{\sqrt{R^2 + (\omega L)^2}} \quad \text{and} \quad \theta = -\tan^{-1}\left(\frac{\omega L}{R}\right),$$

so the final solution for  $i(t)$  is

$$i(t) = \frac{V_o}{\sqrt{R^2 + (\omega L)^2}} \cos\left(\omega t - \tan^{-1}\left(\frac{\omega L}{R}\right)\right)$$

This is the correct solution, but it was a lot of work due to the need for trig identities to deal with the phase shift caused by the inductor. The same technique could be used in a network with multiple inductors and capacitors, but that would result in a much higher-order differential equation, and therefore, a similar, but much more messy, solution procedure.

Is there a better way?

## B. Sinusoidal, steady-state analysis using complex-exponential sources

An improved way of solving this problem is to replace the voltage source  $V_o \cos \omega t$  with its complex-valued “cousin”  $V_o e^{j\omega t}$ . We know from Euler’s identity that

$$V_o e^{j\omega t} = V_o \cos \omega t + jV_o \sin \omega t$$

For this replacement, we can re-draw the schematic as shown below. Here, the complex-valued source is shown as two sources – one real, and the other imaginary. Using the concept of superposition, we can reason that the real-valued source will drive a real-valued current  $i_R(t)$ , and the imaginary-valued source will drive an imaginary-valued current  $i_m(t)$ . We’re interested in the response of this circuit due to the real-valued source, so

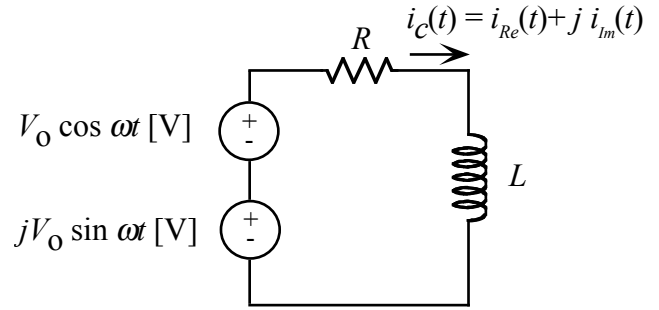

$$i(t) = \text{Re}(i_c(t))$$

where  $i_c(t)$  is the sum of the real and imaginary currents. For this complex-valued source, the differential equation for  $i_c(t)$  is:

$$L \frac{di_c}{dt} + Ri_c = V_o e^{j\omega t}$$

To find  $i_c(t)$ , we can assume it, like the source, is also a complex exponential function of time:

$$i_c(t) = I_m e^{j(\omega t + \theta)} = I_m e^{j\theta} e^{j\omega t}$$

Substituting this into the differential equation, we obtain:

$$j\omega L I_m e^{j(\omega t + \theta)} + R I_m e^{j(\omega t + \theta)} = V_o e^{j\omega t}$$

Each term in this equation contains  $e^{j\omega t}$ , so it can be dropped, yielding

$$j\omega L I_m e^{j\theta} + R I_m e^{j\theta} = V_o$$

Interestingly, this expression does not contain the time variable  $t$ . Solving for  $I_m e^{j\theta}$ , we have:

$$I_m e^{j\theta} = \frac{V_o}{R + j\omega L} = \frac{V_o}{\sqrt{R^2 + (\omega L)^2}} \angle -\tan^{-1}\left(\frac{\omega L}{R}\right)$$

so

$$I_m = \frac{V_o}{\sqrt{R^2 + (\omega L)^2}} \quad \text{and} \quad \theta = -\tan^{-1}\left(\frac{\omega L}{R}\right)$$

Thus, the complex current  $i_c(t)$  is:

$$i_c(t) = I e^{j\theta} e^{j\omega t} = \frac{V_o e^{-j \tan^{-1}\left(\frac{\omega L}{R}\right)}}{\sqrt{R^2 + (\omega L)^2}} e^{j\omega t}$$

and, since  $i(t) = \text{Re}(i_c(t))$ , we finally obtain (using Euler's identity):

$$i(t) = \text{Re} \left[ \frac{V_o}{\sqrt{R^2 + (\omega L)^2}} e^{j\left(\omega t - \tan^{-1}\left(\frac{\omega L}{R}\right)\right)} \right] = \frac{V_o}{\sqrt{R^2 + (\omega L)^2}} \cos\left(\omega t - \tan^{-1}\left(\frac{\omega L}{R}\right)\right)$$

which is the same solution we found using standard time-domain techniques, but without the need for trig identities for handling phase-shifted sines and cosines. This is because the time derivative of  $e^{j\omega t}$  is simply the same function multiplied by  $j\omega$ . And, the solution procedure would not significantly increase in difficulty as more inductors and capacitors were added, since an  $n^{\text{th}}$  order derivative of  $e^{j\omega t}$  is simply  $(j\omega)^n$  times the same function.

### C. Sinusoidal, steady-state analysis using Phasors

Although the use of complex-exponential sources has yielded an improved way of finding the steady-state response of a circuit, we can go further. Looking back at the differential KVL equation we obtained for the  $RL$  circuit for a complex-exponential source,

$$L \frac{di_c}{dt} + Ri_c = V_o e^{j\omega t},$$

we found that when we assumed the solution to be of the form  $i_c(t) = I_m e^{j\theta} e^{j\omega t}$ , yielded

$$j\omega L I_m e^{j\theta} + R I_m e^{j\theta} = V_o$$

If we now define the term  $I_m e^{j\theta}$  to be a *phasor*, which is a complex number that has a magnitude  $I_m$  equal to the peak amplitude of  $i(t)$ , and phase  $\theta$  equal to the phase of  $i(t)$ . Using this definition of  $I$ , we can write

$$j\omega LI + RI = V_o$$

which is a KVL expression that describes the circuit shown below, where the inductor is now represented as an “Ohmic” component with value  $j\omega L$ , the resistor is still a “resistor,” and the sinusoidal voltage source is represented as the phasor  $V_o \angle 0$  (in Volts). This circuit is called the phasor-domain representation of the original time-domain circuit.

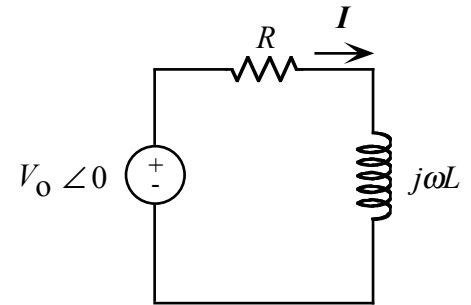

The beauty of the phasor-domain circuit is that it is described by algebraic KVL and KCL equations with time-invariant sources, *not* differential equations of time. The only “cost” is that the impedances of the inductors and capacitors are now complex-valued, so the resulting KVL equations involve complex numbers. But this is a *very* small cost to rid ourselves having to use trig identities to handle the phase-shifted sines and cosines when inductors and capacitors are present. In general, phasor analysis proceeds according to the following steps:

- 1) Represent the time-domain circuit in the phasor domain by treating resistors, inductors and capacitors as “Ohmic” components with impedances (in Ohms) of value  $R$ ,  $j\omega L$  and  $\frac{1}{j\omega C}$ , respectively.
- 2) Represents all the sinusoidal steady-state voltages and currents as phasors according to the rule:

$$V_m \cos(\omega t + \phi) \leftrightarrow V_m \angle \phi \text{ [V]}$$

$$I_m \cos(\omega t + \phi) \leftrightarrow I_m \angle \phi \text{ [A]}$$

- 3) Write KVL and KCL equations for the unknown current and voltage phasors and solve for their values.
- 4) Obtain the time-domain voltage and currents from their phasors.

### D. Laplace analysis

We can analyze the same  $RL$  network (or any other linear network) using Laplace analysis. Laplace analysis can be used for any network with time-dependant sources, but the sources must all have values of zero for  $t < 0$ . This analysis starts by writing the time-domain differential equations that describe the network. For the  $RL$  network we've been considering, this KVL differential equation is:

$$L \frac{di}{dt} + Ri = V_s(t),$$

where  $V_s(t)$  is now considered to be any Laplace-transformable function of time, which is zero for  $t < 0$ . The Lapace transform of this equation is:

$$sLI(s) - Li(0^-) + RI(s) = V_s(s)$$

where  $I(s)$  and  $V_s(s)$  are the Laplace transforms of  $i(t)$  and  $V_s(t)$ , respectively, and  $i(0^-)$  is the current flowing in the inductor at  $t = 0^-$ . This KVL equation suggests the following Laplace-domain circuit. Here, the inductor appears as the series combination of two components: an "Ohmic" component of value  $sL$ , and a voltage source of value  $Li(0^-)$ .

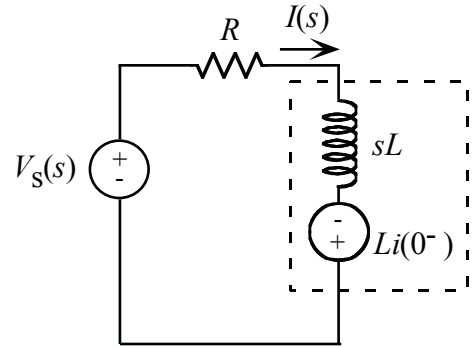
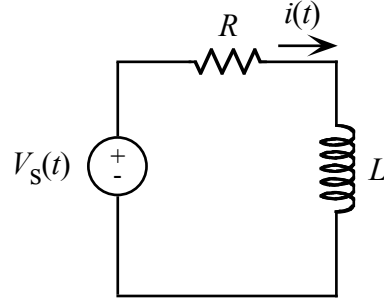

This Laplace transformed KVL equation can be solved for  $I(s)$  algebraically:

$$I(s) = \frac{V_s(s) + Li(0^-)}{sL + R}$$

The desired response  $i(t)$  is simply the inverse Laplace transform of  $I(s)$ .

### a) Steady State Case

As an example, we can find the sinusoidal steady-state response of this network by choosing the source to be  $V_s(t) = V_o \cos \omega t \mathcal{U}(t)$  [V], where  $\mathcal{U}(t)$  is the unit step function. The Laplace transform of this voltage is:

$$V_o \cos \omega t \mathcal{U}(t) [V] \leftrightarrow \frac{sV_o}{s^2 + \omega^2}$$

Substituting this into the expression for  $I(s)$  yields:

$$I(s) = \frac{sV_o}{(s^2 + \omega^2)(sL + R)} + \frac{Li(0^-)}{sL + R}$$

The first fraction on the right-hand side can be expanded as two terms, yielding:

$$I(s) = \frac{as + b}{(s^2 + \omega^2)} + \frac{c}{sL + R} + \frac{Li(0^-)}{sL + R},$$

where  $a$ ,  $b$ , and  $c$  are yet to be determined constants. Using the rules of partial fraction expansion, these constants are found to be:

$$a = \frac{V_o R}{R^2 + (\omega L)^2} \quad b = \frac{V_o \omega^2 L}{R^2 + (\omega L)^2} \quad c = \frac{-V_o R L}{R^2 + (\omega L)^2}$$

The 2<sup>nd</sup> and 3<sup>rd</sup> right-hand terms in the  $I(s)$  expression both correspond to decaying exponentials of the form  $e^{-\frac{R}{L}t} \mathcal{U}(t)$ , so they have no part in the steady state response. Ignoring these terms, we find that the steady state response is:

$$i_{ss}(t) \leftrightarrow \frac{as + b}{(s^2 + \omega^2)}$$

which yields:

$$i_{ss}(t) = a \cos \omega t + \frac{b}{\omega} \sin \omega t \quad \text{for } t > 0$$

Using the values of  $a$  and  $b$  found earlier, this yields, after some trig identities:

$$i_{ss}(t) = \frac{V_o}{\sqrt{R^2 + (\omega L)^2}} \cos \left( \omega t - \tan^{-1} \left( \frac{\omega L}{R} \right) \right) \quad \text{for } t > 0$$

which is the same result as was found more simply using phasor analysis. Of course, the difference here is that Laplace analysis can also give us the transient response.

## b) Step Response Case

As another example, let us consider the response of the same  $RL$  network when  $V_s(t) = V_o \mathcal{U}(t)$  [V], where  $\mathcal{U}(t)$  is the unit step function, then  $V_s(s) = \frac{V_o}{s}$ , so

$$I(s) = \frac{V_o / s + Li(0^-)}{sL + R}$$

whose inverse-Laplace transform is:

$$i(t) = \frac{V_o}{R} (1 - e^{-t/\tau}) + i(0^-) e^{-t/\tau} \quad \text{for } t > 0, \text{ where } \tau = L / R$$

## E. Network Functions

A concept that is useful in both Phasor and Laplace analysis is that of a network transfer function, which relates an input variable (a voltage or current source) to an output variable (some voltage or current). This is depicted in the figure below.

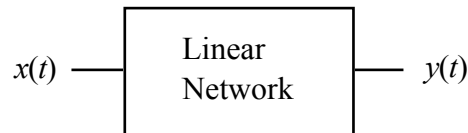

Here, it is assumed that the network is linear and contains no independent sources (although it can contain dependent sources).  $x(t)$  is considered to be the input waveform (either a voltage or a current) and  $y(t)$  is an output waveform (again, either a voltage or a current).

For the case where  $x(t)$  is a continuous sinusoid, the phasors  $X$  and  $Y$  that represent  $x(t)$  and  $y(t)$ , respectively, are always related by:

$$Y = H(\omega)X$$

where  $H(\omega)$  is the network transfer function. For any collection of resistors, capacitors, and inductors,  $H(\omega)$  is always a ratio of polynomials of the frequency  $\omega$ , with coefficients determined by the various component values in the network. For the case of the  $RL$  network we considered earlier, where the voltage source is the input ( $x(t)$ ) and the current  $i(t)$  is the output ( $y(t)$ ), we have

$$H(\omega) = \frac{I}{V} = \frac{1}{j\omega L + R} \quad (RL \text{ network})$$

Similarly, when  $x(t)$  is arbitrary (but Laplace-transformable) and there are no non-zero initial conditions in the network,  $X(s)$  and  $Y(s)$  are related by a similar expression

$$Y(s) = H(s)X(s)$$

Again, for the case of  $RL$  network, we find

$$H(s) = \frac{I(s)}{V(s)} = \frac{1}{sL + R} \quad (RL \text{ network})$$

As can be seen, the network transfer functions  $H(\omega)$  and  $H(s)$  for the  $RL$  network are the same function, except that the  $j\omega$  terms in the former appear as  $s$  terms in the latter. This is no accident. In fact, it is relatively simple to show that this is true for *any* linear network containing resistors, capacitors, inductors, and dependant sources.

If the network transfer function is known, the output of any Laplace-transformable input can be found – in two ways. The first is by taking the inverse-Laplace transform of  $Y(s) = H(s)X(s)$ . For example, consider the response of the  $RL$  network to a unit step function input when there are no initial conditions.. (We will from now on call this the *Step Response* of the network). In this case,  $V(s) = \frac{1}{s}$  and  $i(0^+) = i(0^-) = 0$ , so

$$i_{step}(t) = \mathcal{L}^{-1} \left[ \frac{1}{s(sL + R)} \right] = \frac{1}{R} (1 - e^{-t/\tau}) \mathcal{U}(t) \text{ [V]} \quad (RL \text{ network})$$

Another way of obtaining this same result is to use the Laplace convolution theorem, which states that the inverse transform of a product of s-domain functions equals the convolution of the two time-domain functions. In our case, this means that:

$$y(t) = \mathcal{L}^{-1} [H(s)X(s)] = \begin{cases} \int_0^{\infty} h(\lambda)x(t - \lambda)d\lambda \\ \int_0^{\infty} h(t - \lambda)x(\lambda)d\lambda \end{cases} \quad \text{or} \quad \text{Laplace Convolution theorem}$$

where  $h(t)$  is the inverse-Laplace transform of the network transfer function  $H(s)$ .

As an example, for the  $RL$  network we've been discussing.

$$h(t) = \mathcal{L}^{-1} \left[ \frac{1}{sL + R} \right] = \frac{1}{L} e^{-t/\tau} \mathcal{U}(t) \text{ , where } \tau = L / R$$



Using this, we can find the step-response of the  $RL$  network:

$$i_{step}(t) = \int_0^{\infty} \underbrace{\frac{1}{L} e^{-\lambda/\tau} U(\lambda)}_{h(\lambda)} \underbrace{U(t-\lambda)}_{v_s(t-\lambda)} d\lambda$$

but since  $U(\lambda) = 1$  for all  $\lambda > 0$  and  $U(t-\lambda)$  equals 1 for  $0 < \lambda < t$  and 0 for  $\lambda > t$ , this becomes

$$i_{step}(t) = \int_0^t \frac{1}{L} e^{-\lambda/\tau} d\lambda = \frac{1}{R} (1 - e^{-t/\tau}) U(t) \text{ [V] , (RL network)}$$

which is the same result found before using the inverse Laplace transform technique.

### E. Network Impulse Response

We have already seen that the output  $Y(s)$  of any linear network with network transfer function  $H(s)$  and input  $X(s)$  is:

$$Y(s) = H(s)X(s)$$

From this, it is obvious that  $Y(s)$  and  $H(s)$  will be identical when  $X(s)$  is unity. This happens when  $x(t)$  is the impulse function  $\delta(t)$ , since

$$\delta(t) \leftrightarrow 1$$

So, when the input to a linear network is the impulse function, the output is:

$$y_{impulse}(t) = \mathcal{L}^{-1}(H(s)) \quad (\text{impulse response})$$

In the case of the  $RL$  network we've been considering,

$$i_{impulse}(t) = \mathcal{L}^{-1}(H(s)) = \frac{1}{L} e^{-t/\tau} U(t)$$

This response is unusual, since, unlike the step response, it has a nonzero value at  $t=0^+$ . The reason why this happens is that even though the impulse source is on for an infinitesimal time, its amplitude during this time is infinite, resulting in a step change of  $i$  from  $t=0^-$  to  $t=0^+$

